

User Guide

AES4201

8 x 10 GE | L3



www.aurcore.net

This manual is applicable to AES4201. Unless otherwise specified in the manual, the product diagram shows AES4201 as an example.

Chapter 2 Product Appearance Description

2.1 Front Panel

Introduction of switch front panel:

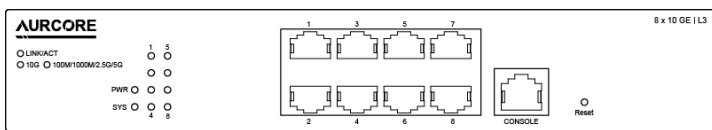

Figure 2-1 Switch front panel diagram

➤ 10M/100M/1000M/2.5G/5G/10Gbps Slots

Support 10M/100M/1000M/2.5G/5G/10Gbps rate adaptive function, support Auto-MDI/MDIX function. And each port has a corresponding indicator, Ports 1-8 are shown on the panel in the upper figure.

➤ Console Port

The Console port is used to connect to the serial port of a computer or other terminal device and to manage or configure the switch.

➤ Reset Switch

A switch that can be automatically reset, long press 5s and release, that is, to restore the factory settings.

2.2 LED Indicator Light

LED	Color	Description
PWR	Green	Death: switch does not power on Permanent: the switch is powered on
SYS	Green	Blinking: the system works Out: the system is starting or has no power
LNK/ACT	Green	Death: not connected to the network equipment Green light: connected to 10/100/1000Mbps devices Blinking: connected devices are data transmission

Packing List

When using the Switch for the first time, carefully open the packing box. The packing box should contain the following items:

- Switch*1
- User Manual*1
- Power Cord*1
- Console Cable*1
- Accessories (Rack Mount Kit*2, Rubber Feet*4, Screw*8)

⚠ **Note:** Precision devices are built in the device, please handle them carefully to avoid violent vibration, which may affect the performance of the device. If you find that the equipment is damaged or any parts are lost in the process of transportation, please inform us, we will give you a proper solution as soon as possible.

Chapter 1 Product Introduction

1.1 Product Overview

Thank you for purchasing this AES4201.

AES4201 is our self-developed Layer 3 Fiber Managed Switch with 8*10GE adaptive RJ45 ports and 1 Console port. It supports static routing function, provides complete security policy, perfect QoS policy and rich VLAN function, easy to manage and maintain, and meets the networking and access requirements of Enterprise, Community, Hotel, Office Network and Campus Network.

1

2.3 Back panel

The rear panel of a Switch shows the AC power port. The power input ranges from 100—240V AC at 50/60 Hz.

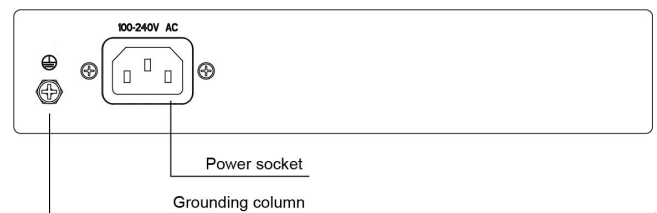

➤ AC Power Port

This is an AC power socket, connect the negative plug of the power cord to this interface, and connect the positive plug to the AC power supply.

➤ Grounding Column

Located on the right side of the power connector, please use a wire to ground to prevent lightning strikes.

⚠ **Precautions:** The product has provision for a permanently connected protective grounding conductor, this conductor need to install to building earth by a skilled person.

Chapter 3 Installation Guide

This chapter helps users correctly install and safely use Switches.

3.1 Installation Precautions

⚠️ **Precautions:** To avoid equipment damage and personal injury, observe the following precautions:

- The Switch room should be dry and ventilated, free from corrosive gases and strong electromagnetic interference.
- The humidity of the Switch equipment room should be lower than 90%. Install proper devices when possible.
- The grounding of the Switch shall comply with the grounding requirements described in this manual, and shall be separately and well grounded.
- The Switch voltage should be stable to prevent abnormal operation of the Switch caused by power supply voltage mutation, fluctuation and other phenomena.
- Keep a proper distance between the Switch and other devices. Do not stack other devices with the Switch.
- The connection cable between the Switch and the distribution frame should be standardized and reasonable, and the distribution frame (box) jumper wire should be concise and clear to prevent the phenomenon of parallel lines and wires.
- To avoid the danger of electric shock, do not open the chassis without authorization; If any fault occurs, contact professional maintenance personnel.

⚠️ **Safety Tips:**

- Use a three-hole socket with safe grounding, and ensure that the PGND cable of the power socket is properly grounded.
- Ensure sufficient space for heat dissipation and ventilation of the Switch. Do not place heavy objects on the Switch.

3.2 Installation Environment

Before installation, make sure that the proper working environment is available, including power requirements, adequate space, proximity to other equipment to be connected, and other equipment in place. Please confirm the following installation requirements:

- Ensure the stability of the workbench and good grounding;
- Environment requirements: The operating temperature ranges from 0°C to 40°C (32°F ~ 104°F) and the working humidity is 10% ~ 90%.

4

3.3 Installation

Rack mounted

- Check the grounding and stability of the cabinet
- Fix mounting ears to both sides of the front panel of the Switch using screws. Place the Switch on a bracket of the cabinet and move the Switch along the guide rails of the cabinet to a proper position;
- Use screws to fix mounting ears to the guide rails at both ends of the cabinet to ensure that the Switch is securely installed on the brackets in the cabinet slots. The mounting ear of the device is not used for weight bearing, it is only used for fixation;
- When installing devices in a cabinet, brackets (fixed on the cabinet) are provided below the device chassis to support devices.

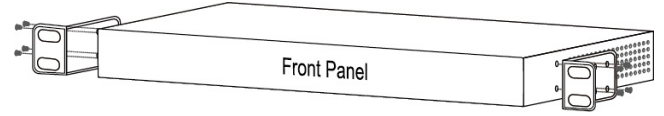

Figure 3-1 Diagram 1 of rack installation

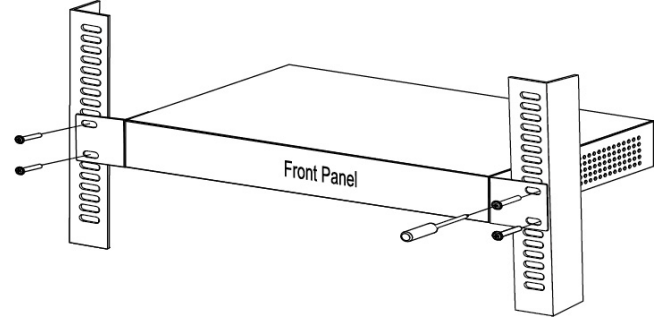

Figure 3-2 Diagram 2 of rack installation

5

Desktop installation

- Place the bottom of the Switch face up on a large enough stable desktop;
- Tear off the attached sticky paper on the surface of the footpad and paste the footpad into the groove at the bottom of the chassis of the Switch to prevent external vibration;
- Carefully position the Switch upright on the workbench.

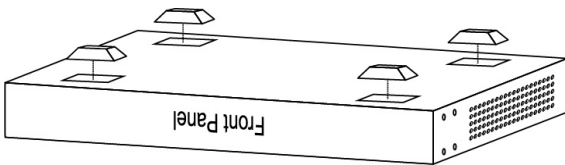

Figure 3-3 Desktop installation diagram

3.4 Turn on Switch

Please connect the AC power cord into the rear of the switch and to an electrical outlet (preferably one that is grounded). When the switch is power on, the LED indicators flash momentarily for one second, which represents a resetting of the system. The Power LED indicator turns on green.

Note: Please confirm the voltage is correct before power on, otherwise the switch will be damaged.

(The power input is:100V-240V AC, 50/60Hz.)

Appendix: Technical Specifications

Model	AES4201
Standard	IEEE802.3, IEEE802.3u, IEEE802.3z, IEEE802.3ab, IEEE802.3x, IEEE802.3af, IEEE802.3at
Network Media	10BASE-T: UTP category 3,4,5 cable (≤100m) 100BASE-TX: UTP category 5 cable (≤100m) 1000BASE-T: UTP category 5e,6 cable (≤100m) 1000Base-X: MMF or SMF SFP Module (optional)
MAC Address Table	8K, Auto-learning, Auto-update
Transfer mode	Store-and-Forward
Frame Forward Rate	10BASE-T: UTP category 3,4,5 cable (≤100m) 100BASE-TX: UTP category 5 cable (≤100m) 1000BASE-T: UTP category 5e,6 cable (≤100m) 1000Base-X: MMF or SMF SFP Module (optional)
Switching Capacity	20Gbps
Dimensions (L*W*H)	280*180*44mm
Fan	1* Fan
Power Input	AC: 100-240V, 50/60Hz
PoE Port	Port1~8
PoE Power on RJ45	Port1-4: 1/2(-),3/6(+) Port5-8: 1/2(+),3/6(-)
PoE Power Output	Voltage: 55V, Power: 30W(Max)
PoE Power Budget	140W
Operating Temperature	0°C ~ 40 °C (32 °F ~ 104°F)
Storage Temperature	-40 °C ~ 70°C (-40 °F ~ 158°F)
Operating Humidity	10% ~ 90% non-condensing
Storage Humidity	5% ~ 90% non-condensing

6

7